

Beam Diagnostics of the SPring-8 Storage Ring

Characteristics of synchrotron radiation (SR) are closely related to those of the source electron beam. For example, pulsed nature of SR is originated from bunched structure of the electron beam. Brilliance of SR is dominated by transverse size and angular divergence of the electron beam. This laboratory course is practice at the SPring-8 diagnostics beamline I (BL38B2).

1) Accelerator diagnostics beamline I (BL38B2).

BL38B2 has a bending magnet light source, and wide band spectral availability from visible light to X-rays has been achieved. The schematic layout of the beamline is shown in Fig.1. The visible synchrotron light is transported to two dark rooms on the experiment hall. Single bunch purity is measured by gated photon counting method in the dark room 2 and bunch length is measured by a streak camera in the dark room 1. X-rays are used in the optics hutch to measure profiles of the electron beam (X-ray beam imager).

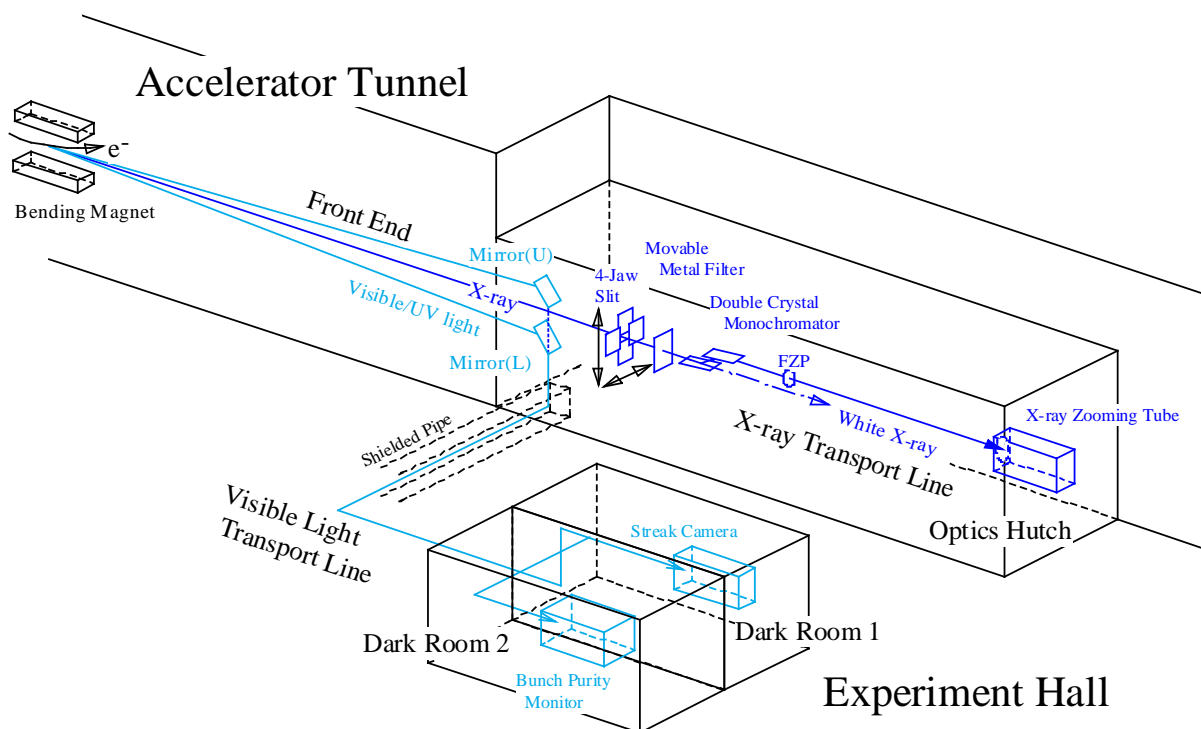

Fig.1 Layout of the accelerator diagnostics beamline I. Components of the beam diagnostics systems are shown.

2) Practice

2-1) Photon counting

When the photon beam is attenuated by slits and filters, we can count photons form each electron bunch one by one (Fig. 2). The counting rate of photons is in proportion to the number of electrons in each bunch. Thus the time spectra of detected photons give us the information on the filling pattern of the storage ring. The block diagram of the photon counting system prepared for the BL practice is shown in Fig. 3.

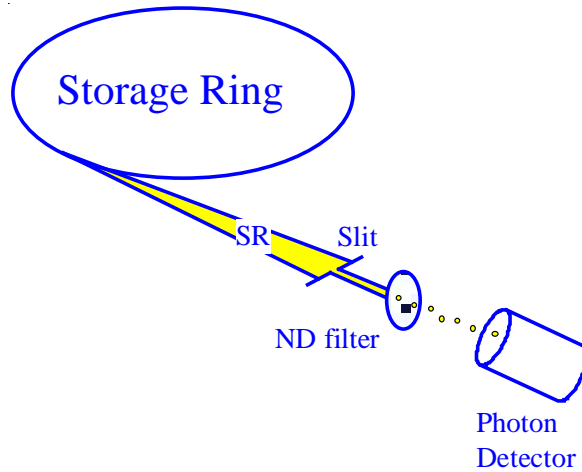

Fig. 2 Concept of photon counting method.

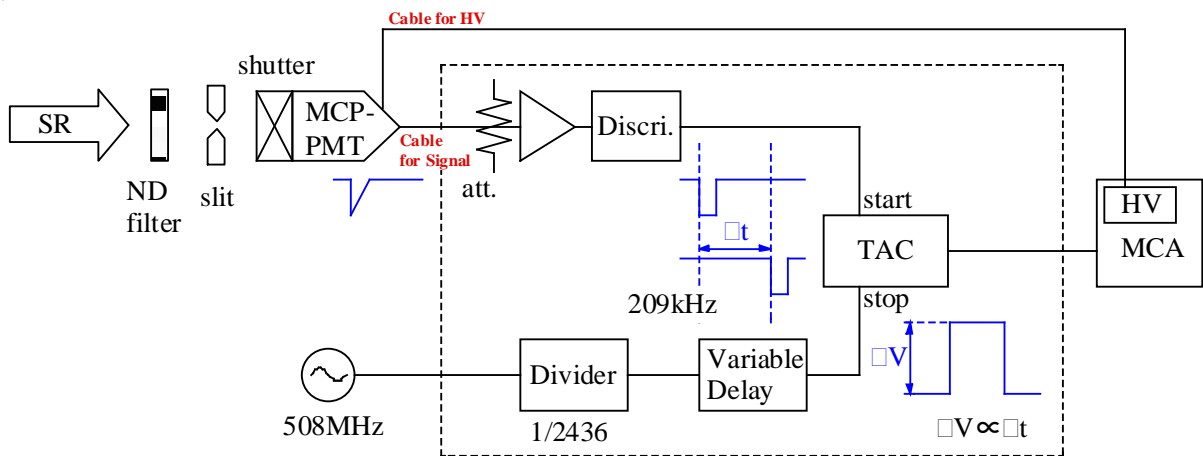

Fig.3 Block diagram of the photon counting system for the BL practice.

2-2) Streak Camera

A streak camera is a fast device to detect short light pulses. The length of SR pulses gives information of the length of electron bunch. The principle of operation of a streak camera is illustrated in Figs. 4 and 5. At the SPring-8, we use the streak camera Hamamatsu C5680 with time resolution of 2 ps. The timing signal system for operating the streak camera is shown in Fig. 6.

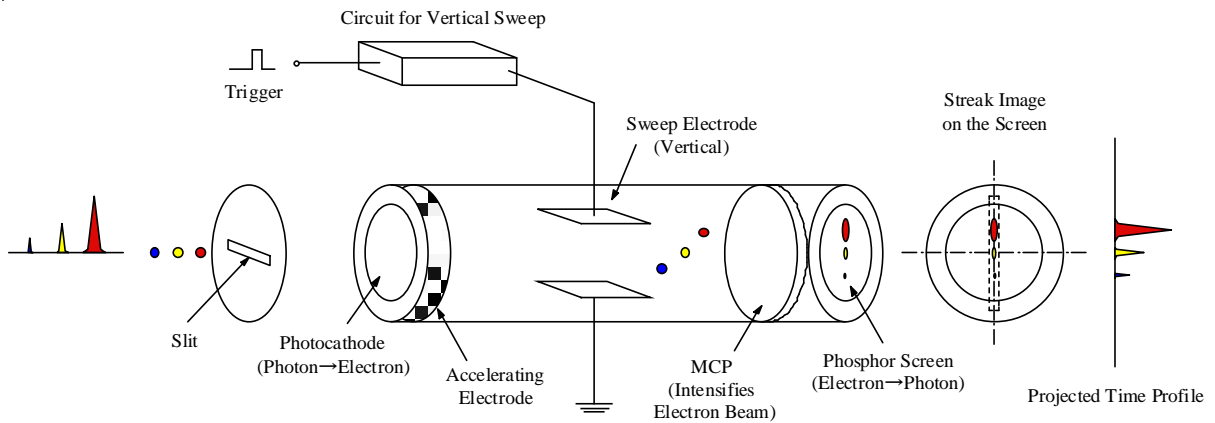

Fig.4 Principle of operation of a streak camera (single sweep mode).

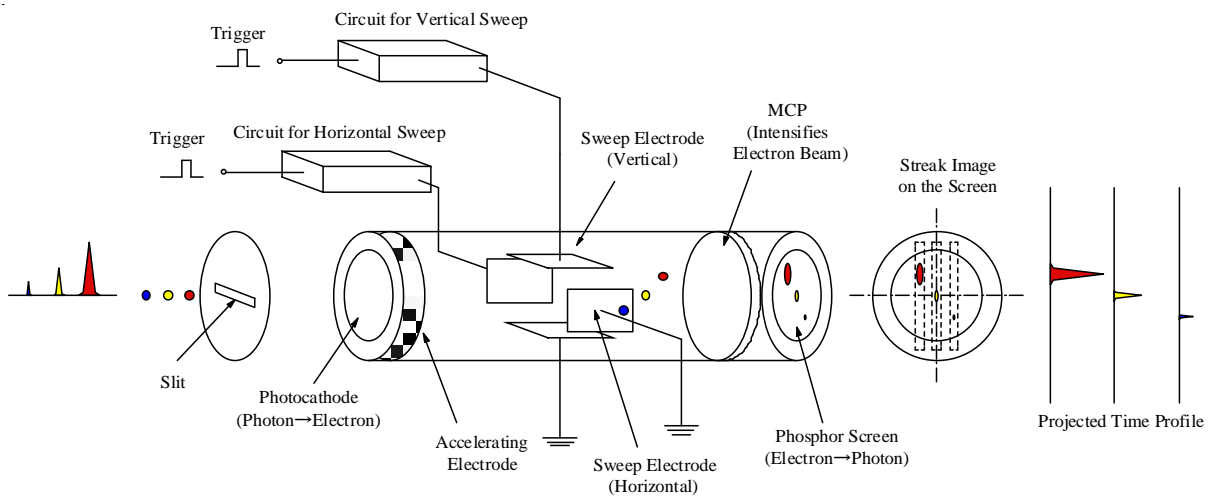

Fig.5 Principle of operation of a streak camera (dual sweep mode).

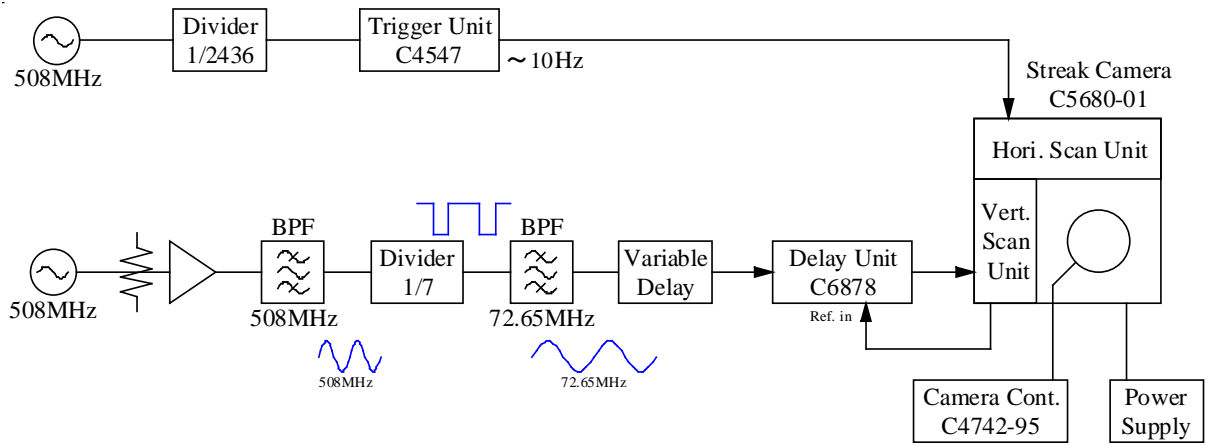

Fig.6 Timing signal system for operating the streak camera.